

See Note #2 for
Mech. Att. Systems.

**WARRANTY NOTE: THIS DETAIL IS
ACCEPTABLE FOR UP TO 15-YEAR
WARRANTIES ONLY. PRE-FABRI-
CATED/PRE-MOLDED FLASHINGS
ARE REQUIRED FOR 20-, 25- AND
30-YEAR WARRANTIES.**

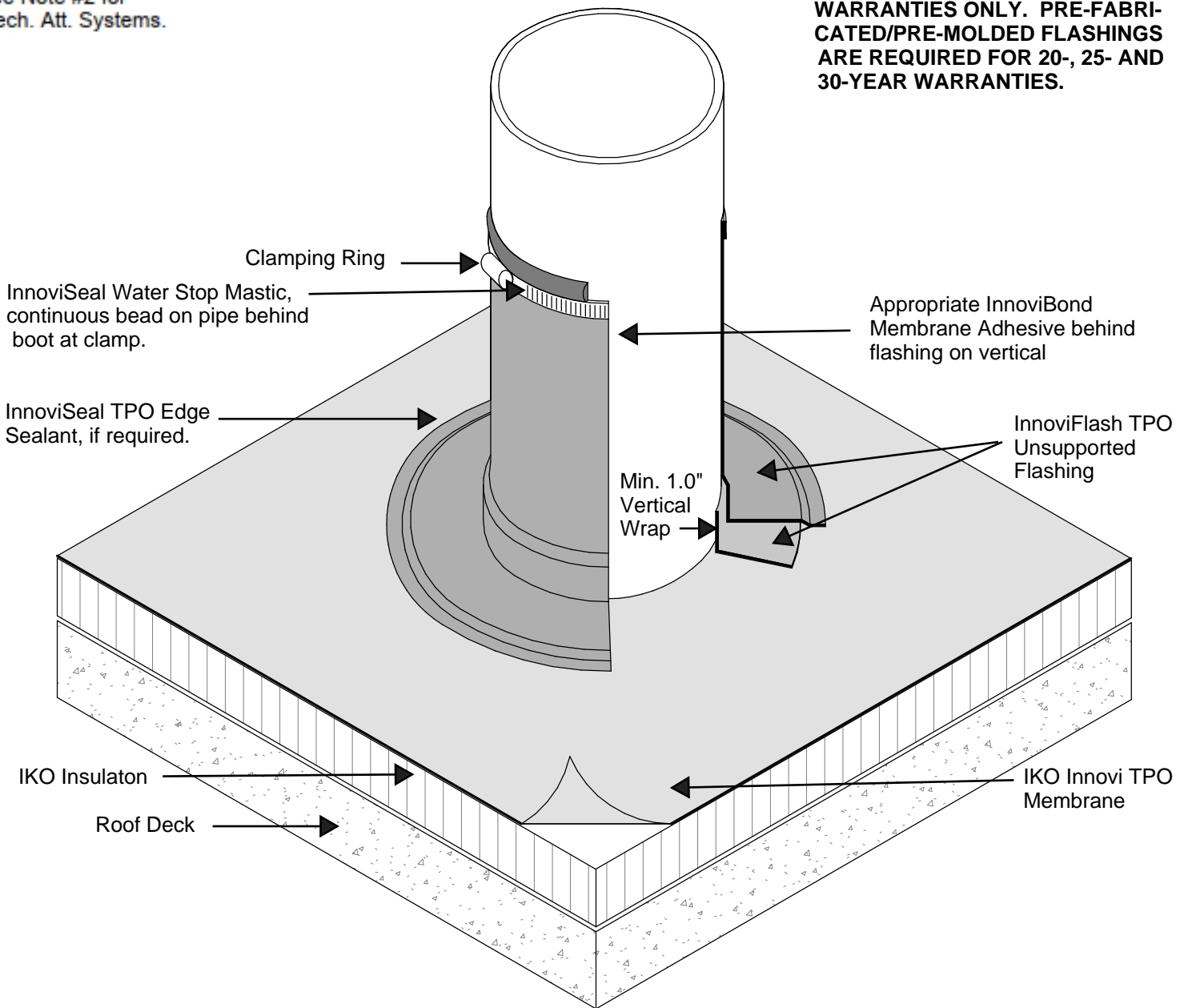

NOTES:

1. Only use a Field Fabricated flashing when a InnoviFlash TPO Universal or Split Pipe Boot cannot be used.
2. For Mechanically Attached Systems, install min. four (4) InnoviFast TPO AP or HD Seam Plates and Fasteners to secure the roof membrane at the base of the pipe, immediately outside of the flashing area. Cut membrane to create a min. 24"x24" Target Patch, centered on the pipe. Install the Target Patch using appropriate InnoviBond Membrane Adhesive, and seal the edges with a continuous bead of InnoviSeal TPO Edge Sealant.
3. Heat weld entire horizontal flashing to roofing membrane.
4. Add a continuous bead of InnoviSeal Water Stop Mastic on pipe behind boot at clamp location.
5. If installing boot over a membrane seam, flash intersections of boot perimeter and membrane seam with InnoviFlash TPO Joint Covers.

FIELD-FABRICATED PIPE WRAP

PF-3