



Application Instructions

ENGLISH

IMPORTANT MESSAGE • PLEASE READ! Products must be applied properly. IKO assumes no responsibility for leaks or defects resulting from poor application or failure to properly prepare the surface to be roofed over, or failure to provide proper ventilation in accordance with minimum property standards requirements. Review all applicable building codes, minimum property standards, and requirements prior to applying these products. Use caution when stacking product on sloped roofs.

These instructions are for a 1-ply application of Roof Fast Cap. This cap product is all that is needed. For two-ply applications, install this cap product after the base product has been applied).

NOTE: If installing a 2-ply roof using Roof-Fast 95 Base as first ply and Roof-Fast Cap as top ply refer to Roof-Fast 95 Base application instructions for first ply. Install top ply of Roof-Fast Cap starting with Step 13.

INSTALLATION TIP: When working on hot days and/or in bright sunlight, allow the product to cool in the shade for a few minutes before removing the release film.

STEP 1:

SURFACE PREPARATION: The roof deck must be clean, smooth, dry and free of sharp protrusions.

- Metal and masonry surfaces must be primed. For re-roofing, remove existing roofing material down to satisfactory deck or acceptable, smooth primed surface. For re-roofing, remove existing roofing material down to satisfactory deck or primed surface.
- Ensure all primed surfaces are completely dry before installation of Roof-Fast. Follow asphalt primer manufacturer's instructions for dry time on asphalt primer. Do not apply Roof-Fast to shingles or other granular-surfaced roof coverings. If the substrate surface is not flat, then voids may occur, which will result in installation difficulties. These installation difficulties could result in a roof that is not watertight.

APPLICATION – EAVE AND RAKE EDGES

STEP 2:

Complete all roof deck and fascia.

STEP 3:

Cut a starter strip of Roof-Fast Cap (Roof-Fast 95 Base/IKO GoldShield may also be used) approximately 12" wide (305 mm).

NOTE: The 12" starter strip assumes that the horizontal drip edge metal flange will be 3" (76 mm) wide, and the vertical face of the edge metal will be with a 2-1/2" (64 mm) long with a 1/2" (13 mm) 30 degree bevel at the lowest edge to divert water away from the building.

STEP 4:

Position the starter strip granule-side down so that there is approximately 9-1/2" (241 mm) on the horizontal surface and 2-1/2" (64 mm) over the vertical face.

NOTE: Leave the release film in place until Roof-Fast installation begins.

STEP 5

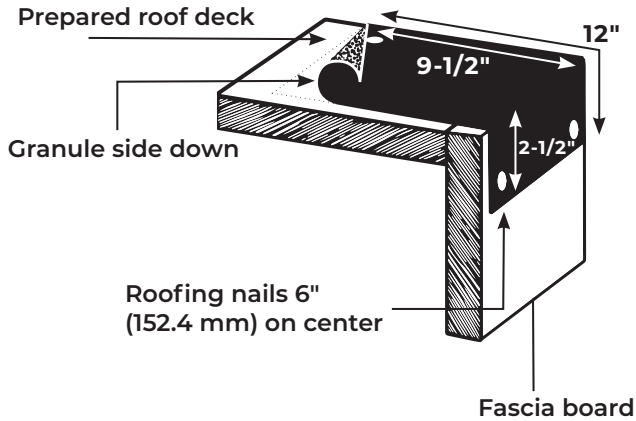

STEP 5:

Fasten the starter strip by nailing the Roof-Fast 6" (152 mm) on center and staggered within the first few inches of the up slope edge and 12" (305 mm) on center on the vertical face.

NOTE:

Be sure to keep the Roof-Fast flat on the horizontal surface to avoid buckles or voids and bend the Roof-Fast as tightly as possible over roof edge prior to fastening on the outside face.

STEP 6

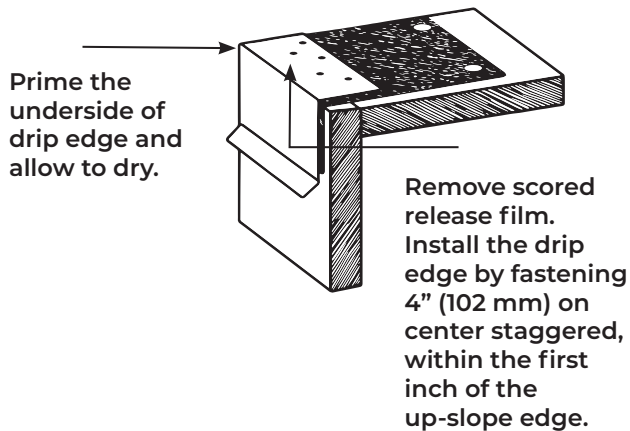

STEP 6:

Score release film the width of the drip edge and tack in place with roofing nails. Install the drip edge by fastening 4" (102 mm) on center staggered within the first inch of the up-slope edge. The stagger should be approximately 1" (25 mm). Face fastening is not recommended on the drip edge metal. Be sure that the horizontal flange of the drip edge metal has been primed.

NOTE:

If your roof has no rake-edge side walls move to Step 13.

APPLICATION – INTERSECTION OF RAKE-EDGE SIDE WALLS

STEPS 7-10

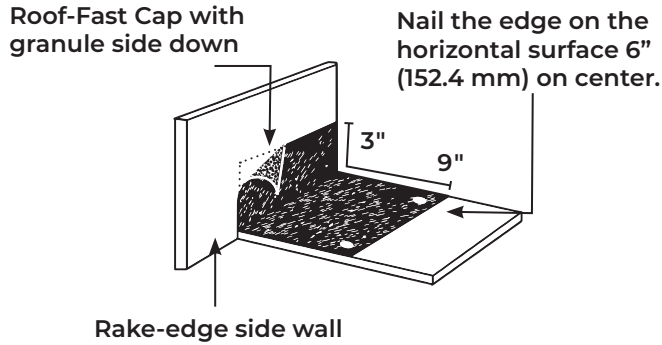

STEP 8:

Cut a starter strip of Roof-Fast Cap approximately 12" (305 mm) wide.

NOTE: The 12" wide starter strip assumes that the L-shaped edge metal will be 3" (76 mm) wide on either side of the 90° break in the metal.

STEP 9:

Position the starter strip granule-side down so that there is approximately 9" (229 mm) on the horizontal surface and 3" (76 mm) up the rake area.

NOTE: Leave the release poly in place until Roof-Fast 95 Base installation begins.

STEP 7:

For existing construction, carefully remove the siding or sheathing in the rake area(s). For new construction, complete the Roof-Fast application prior to siding or sheathing the rake area(s).

STEP 10:

Fasten the starter strip by nailing the Roof-Fast 95 Base 6" (152 mm) on center staggered within the first few inches of the horizontal edge and crease the starter strip at the 90° break.

STEPS 11-12

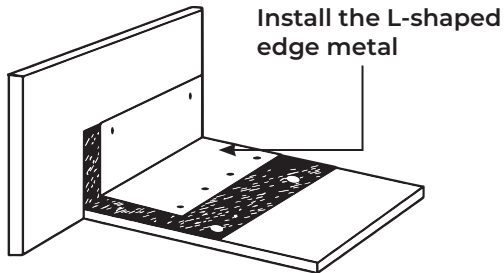

STEP 11:

Install the L-shaped edge metal over the starter strip and fasten 4" (102 mm) on center staggered on the horizontal surface and 12" (305 mm) on center on the vertical surface. The stagger should be approximately 1" (25 mm).

NOTE: Be sure to keep the Roof-Fast flat on the horizontal surface to avoid buckles or voids and crease the Roof-Fast as tightly as possible at the 90° break at the rake prior to anchoring the metal. Be sure that the horizontal flange of the L-shaped metal has been primed prior to fastening. Overlap successive sections of L-shaped metal in shingle fashion, a minimum of 6" (152 mm).

STEP 12:

Once installation of the field of the roof is complete, apply and feather a bead of high-grade exterior caulking at the intersections of where Roof-Fast overlaps with the L-shaped metal.

STEPS 13-15

Eave and Rake Edges

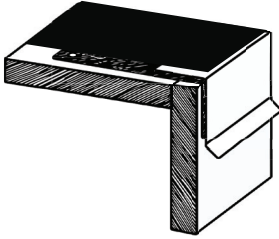

STEP 13:

Unroll and cut the Roof-Fast 95 to the appropriate length. Allow extra material for rake and sloped side details, and trim to exact length during application.

STEP 14:

Position and align the length of Roof-Fast with the granule-side up flush with the drip edge metal at the lowest part of the roof with the film-covered selvage edge on the up-slope side.

INTERSECTION OF RAKE-EDGE SIDE WALLS

Remove release film from starter strip prior to installing Roof-Fast.

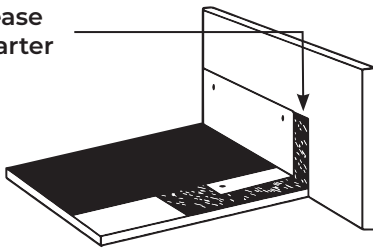

STEP 15:

Re-roll the length of Roof-Fast from both ends towards the middle. Cut the release film along the width of the roll, being careful not to cut the Roof-Fast in the process. A pair of scissors is the best tool for this procedure. Exercise extreme caution if a utility knife is used for this procedure.

STEP 16:

Score the release film on the starter strip next to edge metal flange and remove the release film as the Roof-Fast is being installed.

STEP 17:

As one worker holds the roll in alignment, another worker begins to slowly peel off the release film from the back of the Roof-Fast. The first worker then aligns and presses the Roof-Fast to the primed roof deck, starter strip and drip-edge metal as the release film is being removed. Apply even pressure along the entire length of the membrane (from center to the outside edges) to avoid trapped air or wrinkles. The same process is repeated for the second half of the roll.

STEP 18:

Remove the release film on the starter strips at rake edges and sloped side details prior to completing installation. Trim the Roof-Fast at rake-edge side walls to be flush with the corner of L-Flashing.

STEP 19:

After adhering the Roof-Fast, it is recommended that uniform pressure be applied to the entire roll area (including overlaps onto metal at roof edges and rakes) by a method suitable to the slope of the roof. A steel or silicone roller would be appropriate at seams and metal overlaps. Leave the selvage edge film in place until the next roll is aligned and installed.

STEP 20:

For installation of successive courses, peel back about one-half of the selvage edge release film along the upper edge over the entire length of the side lap. Back-nail at the upper edge of the selvage edge using roofing nails at 4" (102 mm) on center staggered.

STEP 21:

If an end lap (vertical lap) joint must be made, prime the underlying granule surface a minimum of 5" (127 mm), cut a 2" (50 mm) 45° cut at the lower corner and overlap with next roll.

When joining two sheets make a 2" (50 mm) 45° angle cut in the bottom sheet and remove. Overlap the ends of the sheets by a minimum 5" (127 mm). Back-nail bottom roll 4" (102 mm) on center. Use roof cement to cover granules in the overlay.

Uniform pressure must be applied to the entire roll area with a steel or silicone roller.

