



Roof-Fast™ 95 Base

Application Instructions

ENGLISH

IMPORTANT MESSAGE • PLEASE READ! Products must be applied properly. IKO assumes no responsibility for leaks or defects resulting from poor application or failure to properly prepare the surface to be roofed over, or failure to provide proper ventilation in accordance with minimum building code requirements. Review all applicable building codes, minimum property standards, and requirements prior to applying these products. Use caution when stacking product on sloped roofs.

Roof-Fast 95 Base is intended for use as the base ply in a 2-ply assembly using roof-Fast Cap as the top ply. Roof-Fast Base 95 is not designed to be the finished exposed roof membrane. A thin micro-perforated poly-film covers the top surface. The back surfacing is a silicone treated release film, which is easily removed.

These instructions are for the base ply only in a 2-ply system, install this base product first and the Roof-Fast Cap second. See the Roof-Fast Cap instructions for application of the top ply.

INSTALLATION TIP: When working on hot days and/or in bright sunlight, allow the product to cool in the shade for a few minutes before removing the release film.

STEP 1:

SURFACE PREPARATION: The roof deck must be clean, smooth, dry and free of sharp protrusions.

- Wood, concrete, metal and other acceptable substrates must be primed with IKO's S.A.M. Adhesive, S.A.M. Adhesive LVC or an approved equivalent before the application of the IKO Roof-Fast membrane. For re-roofing, remove existing roofing material down to satisfactory deck or primed surface. Roof-Fast Base is also an acceptable substrate for Roof-Fast Cap. When applying Cap over Base, the Base should be clean and dust-free, however, do not prime the Base.

- Ensure all primed surfaces are completely dry before installation of Roof-Fast. Follow asphalt primer manufacturer's instructions for dry time on asphalt primer. Do not apply Roof-Fast to shingles or other granular-surfaced roof coverings. If the substrate surface is not flat, then voids may occur, which will result in installation difficulties. These installation difficulties could result in a roof that is not watertight.

APPLICATION – EAVE AND RAKE EDGES

STEP 2:

Complete all roof deck and fascia.

STEP 3:

Cut a starter strip of Roof-Fast 95 Base approximately 12" (305 mm) wide.

NOTES:

- a)** The 12" wide starter strip assumes that the horizontal edge metal flange will be 3" (76 mm) wide, and the vertical face of the edge metal will be 2-1/2" (64 mm) long with a 1/2" (13 mm) 45 degree bevel at the lowest edge to divert water away from the building; and **b)** The remainder of the Roof-Fast 95 Base should be set aside to be used as the "starter" base sheet to insure that the Roof-Fast 95 Base side laps are off-set from the Roof-Fast Cap side laps.

STEP 5

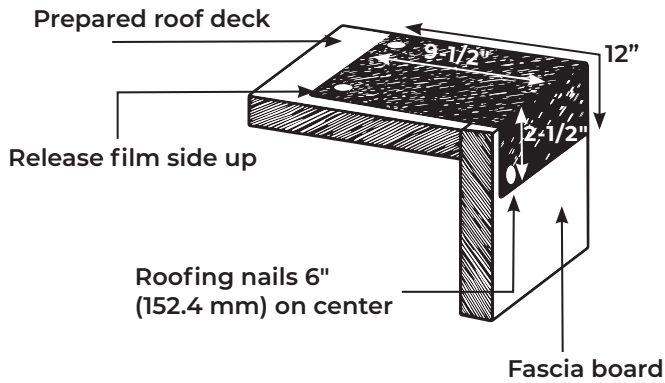

STEP 4:

Position the starter strip (release film side up) so that there is approximately 9-1/2" (241 mm) on the horizontal surface and 2-1/2" (64 mm) over the vertical face.

NOTE:

Leave the release poly in place until Roof-Fast 95 Base installation begins.

STEP 5:

Score release film the width of the drip edge and tack in place with roofing nails. Fasten the starter strip by nailing the Roof-Fast 95 Base 6" (152.4 mm) on center staggered within the first few inches of the up-slope edge and 12" (305 mm) on center on the vertical face.

NOTE:

Be sure to keep the Roof-Fast 95 Base flat on the horizontal surface to avoid buckles or voids and bend the Roof-Fast 95 Base as tightly as possible over roof edge prior to fastening on the outside face.

STEP 6

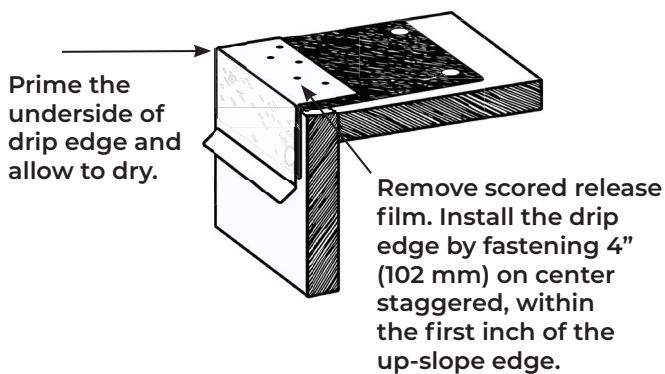

STEP 6:

Remove scored release film. Install the drip edge by fastening 4" (102 mm) on center staggered within the first inch of the up-slope edge. The stagger should be approximately 1" (25 mm). Face fastening is not recommended on the drip edge metal. Be sure that the horizontal flange of the drip edge metal has been primed with asphalt primer.

NOTE:

If your roof has no rake-edge side walls move to Step 13.

APPLICATION – INTERSECTION OF RAKE-EDGE SIDE WALLS

STEPS 7-10

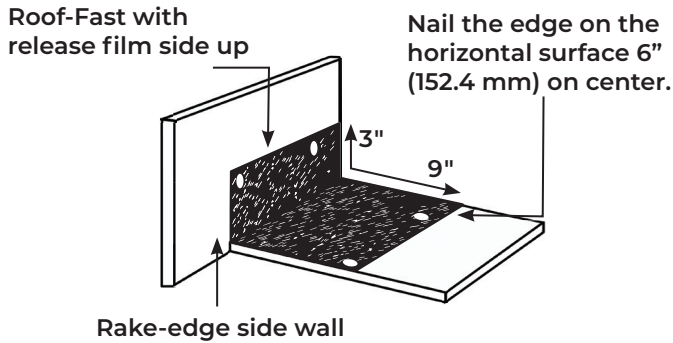

STEP 7:

For existing construction, carefully remove the siding or sheathing in the rake area(s). For new construction, complete the Roof-Fast application prior to siding or sheathing the rake area(s).

STEP 8:

Cut a starter strip of Roof-Fast-95 Base approximately 12" (305 mm) wide.

NOTE: The 12" wide starter strip assumes that the L-shaped edge metal will be 3" (76 mm) wide on either side of the 90° break in the metal.

STEP 9:

Position the starter strip (release film side up) so that there is approximately 9" (229 mm) on the horizontal surface and 3" (76 mm) up the rake area. Note: Leave the release poly in place until Roof-Fast 95 Base installation begins.

STEP 10:

Fasten the starter strip by nailing the Roof-Fast 95 Base 6" (152 mm) on center staggered within the first few inches of the horizontal edge and crease the starter strip at the 90° break.

STEPS 11-12

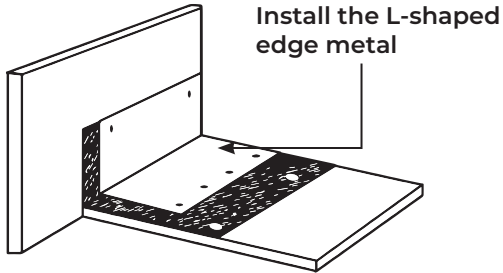

STEP 11:

Prime the horizontal surface of the flashing and let dry before installing Roof-Fast. Remove release film. Install the L-shaped edge metal over the starter strip. Apply and feather a bead of high-grade exterior caulking at the laps. Fasten 4" (102 mm) on center staggered on the horizontal surface and 12" (305 mm) on center on the vertical surface. The stagger should be approximately 1" (25 mm).

NOTE: Be sure to keep the Roof-Fast flat on the horizontal surface to avoid buckles or voids and crease the Roof-Fast as tightly as possible at the 90° break at the rake prior to anchoring the metal. Be sure that the horizontal flange of the L-shaped metal has been primed prior to fastening. Overlap successive sections of L-shaped metal in shingle fashion, a minimum of 6" (152 mm).

STEP 12:

IMPORTANT – Once installation of the finish ply of Roof-Fast Cap membrane is complete apply a 1/4" bead of high-grade exterior caulk to seal the edge of the Roof-Fast Cap and the metal angle.

STEPS 13-15

Eave and Rake Edges

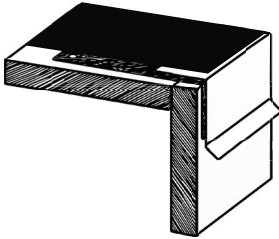

INTERSECTION OF RAKE-EDGE SIDE WALLS

Remove release film from starter strip prior to installing Roof-Fast.

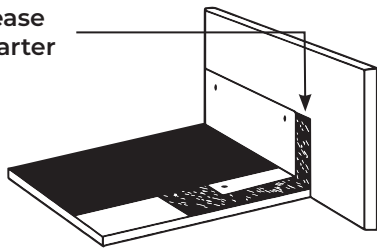

STEP 13:

Unroll and cut the Roof-Fast 95 Base to the appropriate length. Allow extra material for rake and sloped side details, and trim to exact length during application. IKO recommends that the remainder of the width used to create the starter strip be used for the first run of Roof-Fast 95 Base. This will ensure that the Roof-Fast 95 Base side laps and Roof-Fast Cap side laps are offset.

STEP 14:

Properly position and align the length of Roof-Fast 95 Base over the edge metal at the lowest part of the roof with the selvedge on the up-slope side. Fold back the roll length-wise to expose the perforation in the release film on the back of the roll. Remove the release film from the down-slope portion of the roll. It is important that the Roof-Fast 95 Base not be repositioned during the folding and removal of the release film.

STEP 15:

Lightly score and remove the release film from the starter strip at the edge metal. Unfold the Roof-Fast 95 Base and allow it to fall into place over the starter strip and the edge metal. Smooth the Roof-Fast 95 Base in place to initiate contact with the substrate, starter strip and edge metal. Remove the remaining release film from the up-slope portion of the roll and smooth in place. Fasten the Roof-Fast Base at 18" O.C. in one row down the approximate center of the starter sheet leaving upper edge free of fasteners for later steps in installation. Lay out a full width base sheet up the slope overlapping the starter sheet by a minimum of 3". Fasten through the overlap with 1" disk nails 9" O.C. working from the center of the sheet outwards.

STEP 16:

Install successive sheets of Roof-Fast 95 Base in a similar manner by aligning the side overlap with the painted line on the selvedge. Remove the release film from the underlying roll's selvedge and back-nail the selvedge 4" on center. Remove release film from overlying roll and smooth into place. Remove release film from starter strips at rake edges and sloped side details prior to completing installation.

STEP 17:

If end laps are necessary, lap successive sections of Roof-Fast 95 Base six (6") inches (152 mm). Roof-Fast 95 Base end laps must be staggered a minimum of two feet (610 mm) from Roof-Fast Cap sheet end laps and nailed 9" (229 mm) O.C. (see instructions for installation of endlap details). Ensure the sheet lays flat and wrinkle-free at all times. Fasten the center of the sheet in 2 rows at 18" O.C. in a staggered formation starting from the center and working outwards.

STEP 18:

After adhering the Roof-Fast 95 Base sheets, it is recommended that uniform pressure be applied to the entire roll area (including overlaps onto metal at roof edges and rakes) by a method suitable to the slope of the roof. A steel or silicone roller would be appropriate at seams and metal overlaps. This is the first layer of the 2-ply system.