

InnoviFlashTM TPO Universal Corner

Stock #: 6200001, 6227170

Material: .60 mil (1.52 mm),
injection-grade, weldable IKO InnoviTPO

Standard size: 10 in. (254 mm) x 10 in. (254 mm)
x 3 in. (76.2 mm)

Color: White, Grey

Packaging: 20/box, 6.0 lbs. (2.7 kg)/box

All reported values are nominal.

- One molded part with both inside and outside corner capabilities.
- Ideal flashing for a wide range of corner conditions.
- Factory fabrication ensures quality.

System Compatibility

InnoviFlash TPO Universal Corners are intended for use with IKO InnoviTPO Roofing Systems and are approved for use with an appropriate IKO Diamond Shield Limited Warranty. Building owners, specifiers, roof consultants and roofing contractors are invited to review the IKO InnoviTPO System Specifications at www.iko.com/innovi for further information on including this product as part of a complete IKO roofing system.

Universal Corners Fit A Wide Range of Flashing Conditions

InnoviFlash TPO Universal Corners are made from 60 mil (1.52 mm) injection-grade, weldable TPO, and are ideal for flashing a multitude of demanding roof details. Field installation is as easy as heat-welding the TPO Universal Corner to the roofing membrane, per IKO details. The injection molded design offers a better fit and more uniform appearance than field-formed or pre-formed corner flashings.

Prefabrication Ensures Top Quality

Factory fabrication under strict quality manufacturing controls makes the InnoviFlash TPO Universal Corner ideal for quality control for the entire roofing installation. A contractor can save significant fabrication time, resulting in considerable labor savings.

InnoviFlash[™] TPO Universal Corner

Installation

1. Prepare all welding surfaces by cleaning with InnoviPrime[™] TPO Pre-Wash membrane cleaner.
2. Cut the InnoviFlash TPO Universal Corner per the diagram(s) below to fit the appropriate corner type needed.
3. Center the corner where both vertical faces meet and intersect the roof deck
4. Begin welding at the centermost point, progressively working outwards.
5. Probe the edge of the membrane on all three faces.

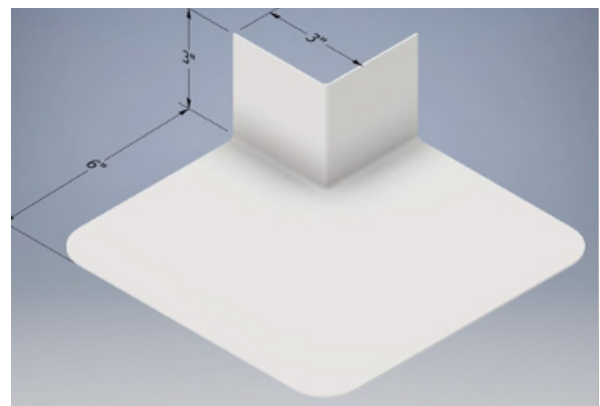
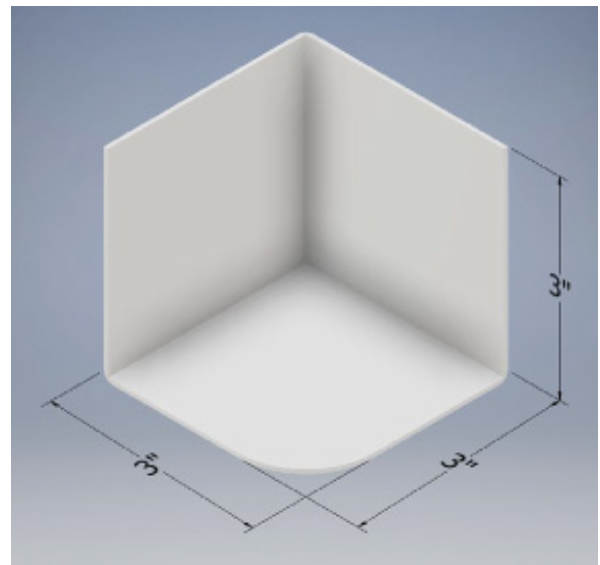
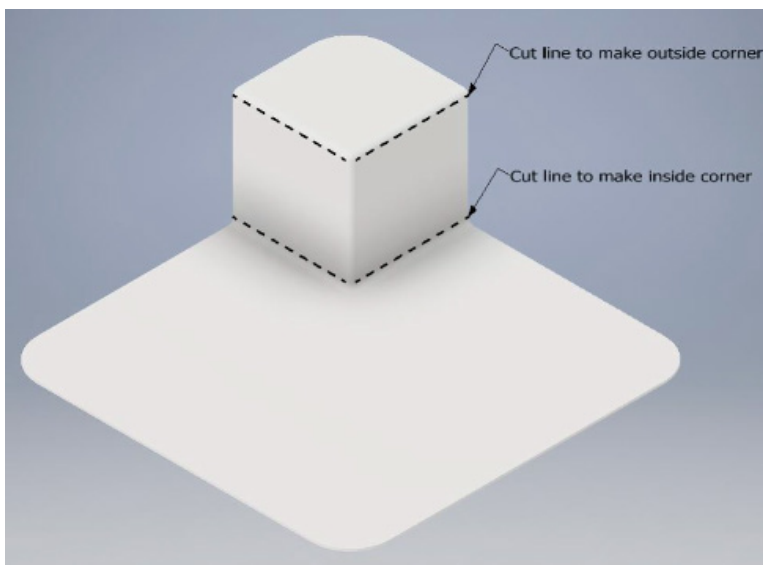

The information on this sheet is based on data supplied by the manufacturer to IKO and believed to be true and accurate. The information is offered solely for the user's consideration, investigation and verification. Nothing contained herein constitutes or represents a warranty or guarantee for which the manufacturer or the distributor can be held legally responsible.